

Honeywell

THE V800 FAMILY OF COMBINATION GAS CONTROLS PERFORMS ALL THE FUNCTIONS REQUIRED IN THE BURNER MANIFOLD ON GAS-FIRED HEATING EQUIPMENT.

- Available in 7 capacity ratings.
- Suitable for use on domestic equipment from small individual room heaters to large central heating units.
- Provides 3-position (OFF-PILOT-ON) manual control of gas flow.
- Available in standard opening and step opening pressure regulator models.
- Can be mounted from 0 to 90 degrees from the vertical position of the gas control knob.
- El Controls with the prefix "V" require 30 mV thermocouple and suitable pilot burner.
- Controls with the prefix "VS" require 750 mV thermopile generator in a self-generating Powerpile system.
- If gas or power supply is interrupted, main gas valve is closed.
- In case of pilot flame failure, main valve is closed.

COMBINATION GAS CONTROLS

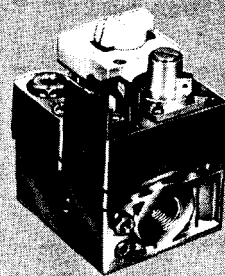

24 VOLT

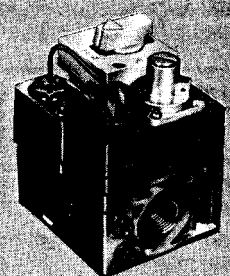

POWERPILE

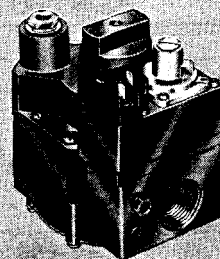

HIGH
CAPACITY

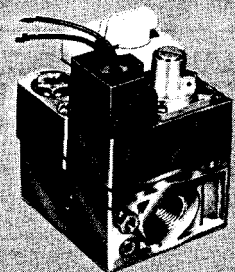

120 VOLT

**THE V800 FAMILY
110 cfh [3.1 m³/hr]
SERIES
FOR HEATING
APPLIANCES
180 cfh [5.1 m³/hr] TO
600 cfh [17 m³/hr] SERIES
FOR CENTRAL HEATING**

SPECIFICATIONS

IMPORTANT

THE SPECIFICATIONS GIVEN IN THIS PUBLICATION DO NOT INCLUDE NORMAL MANUFACTURING TOLERANCES. THEREFORE, THIS UNIT MAY NOT MATCH THE LISTED SPECIFICATIONS EXACTLY. ALSO, THIS PRODUCT IS TESTED AND CALIBRATED UNDER CLOSELY CONTROLLED CONDITIONS, AND SOME MINOR DIFFERENCES IN PERFORMANCE CAN BE EXPECTED IF THOSE CONDITIONS ARE CHANGED.

SUPER TRADELINE MODELS

SUPER TRADELINE controls offer features not available on TRADELINE or standard models, and are designed to replace a wide range of Honeywell and competitive controls.

SUPER TRADELINE MODELS AVAILABLE:

V800A Combination Gas Control with 3/4 in. inlet and 3/4 in. straight through outlet and 1/2 in. left-hand and right-hand side outlets.

VS820A Combination Gas Control with Powerpile and 3/4 in. inlet and 3/4 in. straight through outlet and 1/

2 in. left-hand and right-hand side outlets.

ADDITIONAL FEATURES:

- Left and right side outlets in addition to the straight-through outlet. Refer to Fig. 3.
- Ambient Temperature Range: Models available for 32° F to 175° F [0° to 79° C].
- Reducer fittings included to fit variety of sizes.
- TRADELINE pack with cross reference label and special instruction sheet.

TRADELINE MODELS

TRADELINE models are selected and packaged to provide ease of stocking, ease of handling and maximum replacement value. Specifications of SUPER TRADELINE and TRADELINE controls are the same as those of standard models except as noted below.

TRADELINE MODELS AVAILABLE:

V400A Combination Gas Control with either 1/2 in. left-hand or right-hand side outlet.

V800A,C Combination Gas Control with either 1/2 in. left-hand or right-hand side outlet.

VS820A,C Combination Gas Control with either 1/2 in. left-hand or right-hand side outlet.

ADDITIONAL FEATURES:

- Left and right side outlets in addition to the straight-through outlet. Refer to Fig. 3.
- Ambient Temperature Range: Models available for 32° F to 175° F [0° C to 79° C].
- Reducer fittings included to fit variety of sizes.
- TRADELINE pack with cross reference label and special instruction sheet.

STANDARD MODELS

MODELS: Refer to Table 1 for model specifications.

V400—120V combination gas control with magnetic type operator.

V800—24V combination gas control with magnetic type operator.

V801—24V combination gas control with magnetic type operator.

VS820. VS821—Millivoltage combination gas control with Powerpile operator.

(continued on page 3)

ORDERING INFORMATION

WHEN PURCHASING REPLACEMENT AND MODERNIZATION PRODUCTS FROM YOUR TRADELINE WHOLESALE OR YOUR DISTRIBUTOR, REFER TO THE TRADELINE CATALOG OR PRICE SHEETS FOR COMPLETE ORDERING NUMBER, OR SPECIFY:

1. Order number.
2. Inlet and outlet size.
Indicate standard or high-capacity
3. Supply voltage and frequency.
4. Energy cutoff (ECO) connector, if required.
5. Optional specifications, if desired.
6. Order separately: pilot burner, thermocouple or generator, transformer, limit controller, and thermostat or controller.

IF YOU HAVE ADDITIONAL QUESTIONS, NEED FURTHER INFORMATION, OR WOULD LIKE TO COMMENT ON OUR PRODUCTS OR SERVICES, PLEASE WRITE OR PHONE:

1. YOUR LOCAL HONEYWELL RESIDENTIAL DIVISION SALES OFFICE (CHECK WHITE PAGES OR PHONE DIRECTORY).
2. RESIDENTIAL DIVISION CUSTOMER SERVICE
HONEYWELL INC., 1885 DOUGLAS DRIVE NORTH
MINNEAPOLIS, MINNESOTA 55422 (61 2) 542-7500

(IN CANADA—HONEYWELL CONTROLS LIMITED, 740 ELLESMERE ROAD, SCARBOROUGH, ONTARIO MI P 2V9) INTERNATIONAL SALES AND SERVICE OFFICES IN ALL PRINCIPAL CITIES "F THE WORLD.

TABLE I—MODEL SPECIFICATIONS.

MODEL NO. SUFFIX LETTER	AMBIENT TEMPERATURE RANGE	PRESSURE REGULATOR TYPE	PRESSURE REGULATOR MODEL	TYPE OF GAS	STANDARD FACTORY SETTINGS	
					in. wc	kPa
A	32° F to 175° F [0° c to 79° c]	Standard	V5306	Nat. LP	3.5 11.0	0.9 2.7
c	32° F to 175° F [0° c to 79° c]	Step-opening	V5307	Nat.	0.9 step 3.5 full rate	0.2 step 0.9 full rate
				LP	2.2 step 11.0 full rate	0.5 step 2.7 full rate
H	32° F to 175° F [0° c to 79° c]	Standard (Delayed opening)	V5306	Nat.	3.5	0.9
				LP	11.0	2.7
M	-40° F to 175° F [-40° c to 79° c]	Standard	V5306	Nat.	3.5	0.9
				LP	11.0	2.7
P	-40° F to 175° F [-40° c to 79° c]	Step-opening	V5307	Nat.	0.9 step 3.5 full rate	0.2 step 0.9 full rate
				LP	2.2 step 11.0 full rate	0.5 step 2.7 full rate

CAPACITIES AND PIPE SIZES: Refer to Table 2 for capacity and pipe sizes. Capacity is the same with or without the pressure regulator.

TABLE 2—CAPACITIES AND PIPE SIZES^a.

INLET OUTLET SIZE	CAPACITY ^b cfh	CAPACITY ^b m ³ /hr	MODEL NUMBER
1/2 x 3/8	110	3.1	V801, VS821
1/2 x 1/2	225	5.1	V400, V800, V810, VS820
1/2 x 3/4	250	5.8	
3/4 x 3/4	335	5.9	HIGH CAPACITY V400, V800, V810, VS820
3/4 x 3/4	450	12.7	
3/4 x 1	503	14.2	
1X1	600	17.0	

^aAll models have leak limiting orifice.

^bCapacities are based on 1000 BTU/ft³, 0.64 specific gravity natural gas at 1 in. wc pd. [37.3 MJ/m³, 0.64 specific gravity natural gas at 0.25 kPa pd.]. Use conversion factors (upper right) to convert to other gases.

GAS	SPECIFIC GRAVITY	MULTIPLY LISTED CAPACITY BY
Manufactured	0.60	0.516
Mixed	0.70	0.765
Propane	1.53	1.62

ELECTRICAL CONNECTIONS:

VALVE OPERATOR	TYPE CONNECTION
100V, 120V, and 220/240V	36 in. [0.9 mm] leadwires (2)
24V and Powerpile	Combination screw and quick-connect (1/4 in. male)

THERMOSTAT HEAT ANTICIPATOR SETTING:

24V Models: 0.2A.

100V, 120V, 220/240V, Powerpile Models: Not applicable.

PILOT GAS OUTLET: Compression fitting for 1/4 in. OD tubing.

PRESSURE TAPPING: Taps are 1/8 in, NPT with plug containing recess for 3/16 in. Allen wrench. Outlet tap standard, inlet tap available; specify when ordering.

PRESSURE RATING: A.G.A. rating 1/2 psi [3.5 kPa] inlet pressure. Designed for safe operation up to 28 in. wc [7.0 kPa].

MOUNTING: All models can be mounted from 0 to 90 degrees from the vertical position of the gas control

knob.

DIMENSIONS: Refer to Figs. 1 and 2.

APPROVALS:
 AMERICAN GAS ASSOCIATION DESIGN CERTIFICATE: P-G-774A.
 UNDERWRITERS LABORATORIES INC. COMPONENT RECOGNIZED: File No. MH5323, Guide No. MCC22.
 DIN APPROVAL: No. 76. 01c.050 only on the V400C5011

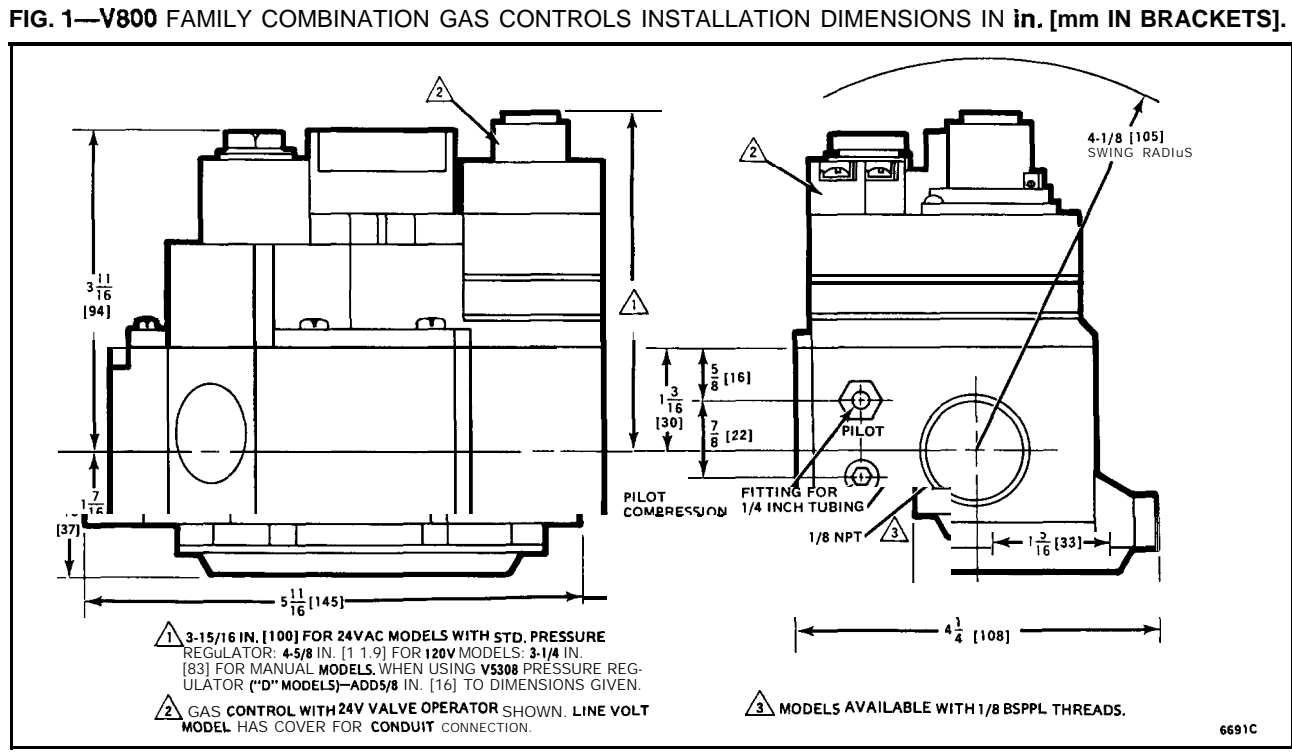
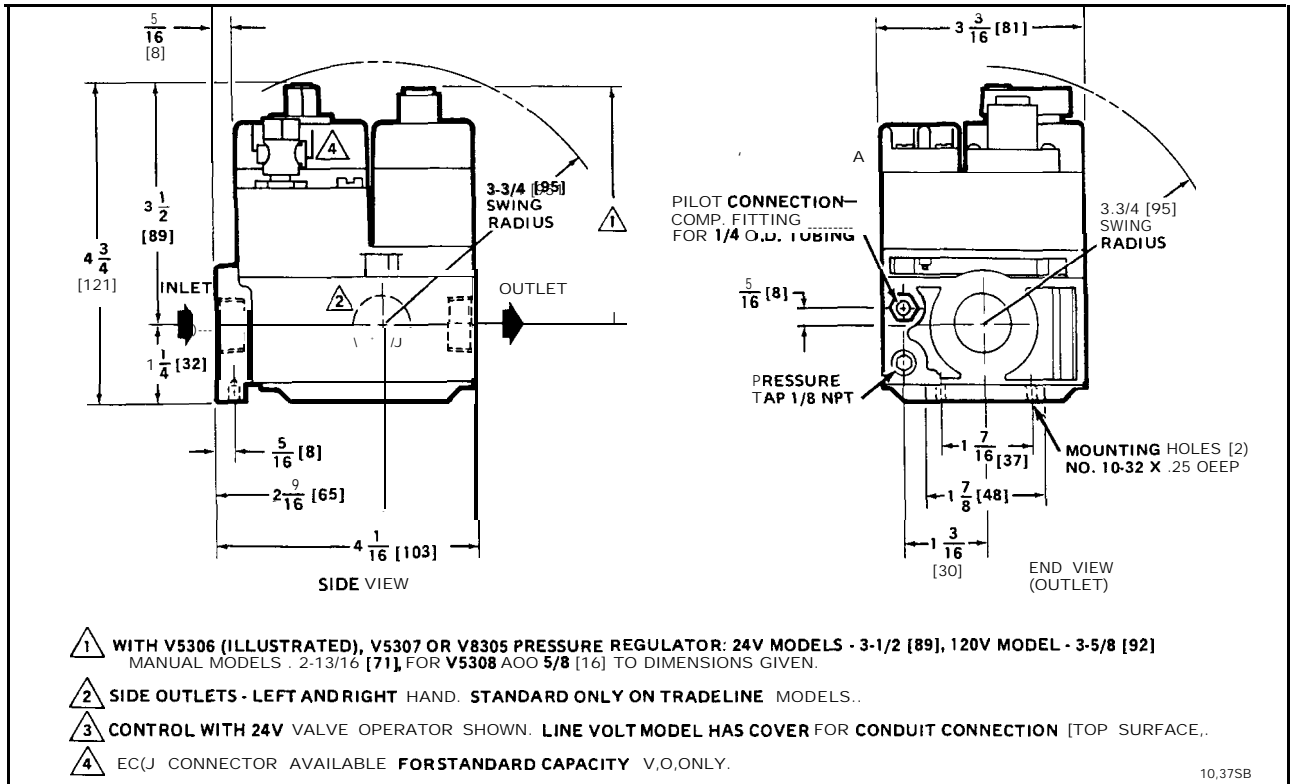

FIG. 2—V800 FAMILY HIGH CAPACITY COMBINATION GAS CONTROLS INSTALLATION DIMENSIONS in in. [mm IN BRACKETS].

high capacity 1 in. BSPP by 1 in. BSPP gas control. THERMOCOUPLE REQUIRED (ordered separately) for 24V, 100V, 120V, and 220/240V models: Q309 or Q340 suggested.

Nominal output: 30 mV, 0.02 ohms,
Open circuit turndown voltage: 2mV.

POWERPILE GENERATOR REQUIRED (order separately) for 750 mV models: Q302 or Q313 suggested.

Nominal output: 750 mV, 3.4 ohms.

Open circuit turndown voltage: 141 mV.

OPTIONAL SPECIFICATIONS:

1. Inlet pressure tap, 1/8 in. NPT.

2. Side outlets.

REPLACEMENT PARTS:

1.392451-1 Energy Cutoff (ECO) Connector.

2. Valve Operators:

Powerpile Operator: VS824.

Modusnap operator with modulating control: V5306.

3. Servo Gas Pressure Regulators.

Standard pressure regulator: V5306.

Step-opening pressure regulator: V5307.

INSTALLATION

WHEN INSTALLING THIS PRODUCT...

1. Read these instructions carefully. Failure to follow instructions can damage product or cause a hazardous condition.

2. Check ratings given in instructions and on product to make sure product is suitable for your application.

3. Make sure installer is a trained, experienced service technician.

4. After completing installation, use these instructions to check out product operation.

WARNING

FIRE OR EXPLOSION HAZARD

CAN CAUSE PROPERTY DAMAGE, SEVERE INJURY, OR DEATH

Follow these warnings exactly.

1. To avoid dangerous accumulation of fuel gas, turn off gas supply at appliance service valve before starting installation and perform Gas Leak Test after completion of installation.
2. Do not bend pilot tubing at the control or pilot after compression nut has been tightened. Gas leakage at the connection may result.
3. Always install sediment trap in gas supply line to prevent contamination of gas control.
4. Do not force gas control knob. Use only your hand to turn gas control knob. Never use any tools. If gas control knob will not operate by hand, the control should be replaced by a qualified service technician. Force or attempted repair may result in fire or explosion.

CAUTION

1. Disconnect power supply before wiring to prevent electrical shock or equipment damage.
2. Never apply a jumper across (or short) valve coil terminals. This may burn out heat anticipator in thermostat.

IMPORTANT

These gas controls are shipped with protective seals over inlet and outlet tappings. Do not remove seals until ready to connect piping.

OPTIONAL PIPING PATTERNS—

TRADELiNE MODELS

To facilitate installation, TRADELINE models incorpo-

rate side outlets in the standard straight-through body. Refer to Fig. 3.

To fit existing piping, reducer fittings also are included.

These controls are shipped with side outlets plugged as shown. If connection is made to optional side outlet, be sure to install plug in standard straight-through outlet tapping. Use plug removed from side outlet.

Perform Gas Leak Test when installation is complete.

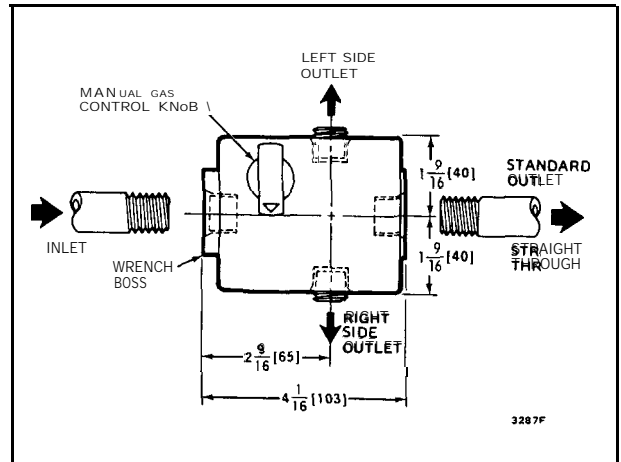

FIG. 3—TRADELiNE OPTIONAL SIDE OUTLETS (standard capacity models only).

Follow appliance manufacturer's instructions if available; otherwise, use instructions provided below as a guide.

LOCATION

Do not locate the combination gas control where adverse environments such as steam cleaning, high humidity or dripping water, corrosive chemicals, dust or grease accumulation, or excessive heat are prevalent. To ensure proper operation, follow these guidelines:

- Locate in a well ventilated area.
- Mount high enough above the cabinet bottom to avoid exposure to flooding or splashing water.
- Ensure that the ambient temperature does not exceed the ambient temperature ratings for each component.
- Cover if appliance is cleaned with water, steam, or chemicals or to avoid dust and grease accumulation.
- Avoid locating where exposure to corrosive chemical fumes or dripping water is likely.

Mount the combination gas control in the appliance vestibule on the gas manifold. If this is a replacement application, mount the control in same location as old control.

INSTALL PIPING TO CONTROL

All piping must comply with local codes and ordinances or with National Fuel Gas Code (ANSI Z223.1 NFPA No. 54), whichever applies. Tubing installation must comply with approved standards and practices.

1. Use new, properly reamed pipe free from chips. If tubing is used, make sure ends are square, deburred, and clean. All tubing bends must be smooth and without deformation.

2. Run pipe or tubing to the control. If tubing is used, obtain a tube-to-pipe coupling to connect tubing to the control.

3. Install sediment trap in gas supply line. Refer to Fig. 4.

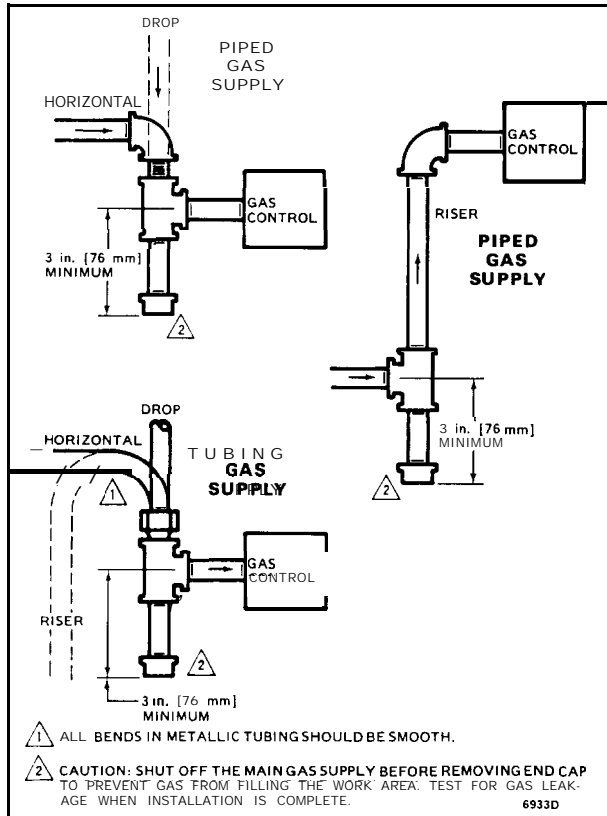

FIG. 4—SEDIMENT TRAP INSTALLATION.

INSTALL CONTROL

1. This control can be mounted 0-90 degrees, in any direction, from the upright position of the gas control knob, including vertically.

2. Mount the control so gas flow is in direction of arrow on bottom of control.

3. Thread pipe the amount shown in Table 6 for insertion into control. DO NOT THREAD PIPE TOO FAR. Valve distortion or malfunction may result if pipe is inserted too deeply.

TABLE 6—NPT PIPE THREAD LENGTH (in.).

PIPE SIZE PIPE SIZE	THREAD PIPE THIS AMOUNT	MAXIMUM DEPTH PIPE CAN BE INSERTED INTO CONTROL
3/8	9/16	3/4
1/2	3/4	1/2
3/4	13/16	3/4

4. Apply a moderate amount of good quality pipe compound (DO NOT use Teflon tape) to pipe only, leaving two end threads bare. On LP installations, use compound resistant to LP gas. Refer to Fig. 5.

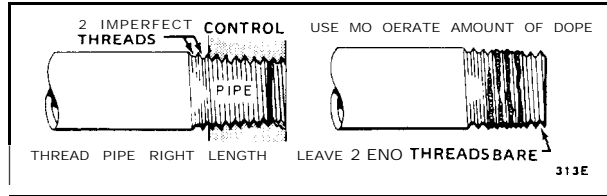

FIG. 5—USE MODERATE AMOUNT OF PIPE COMPOUND.

5. Remove seals over control inlet and outlet, if necessary.

6. Connect pipe to control inlet and outlet. To tighten inlet and outlet connections, use wrench on projecting wrench boss. Refer to Figs. 6 and 7.

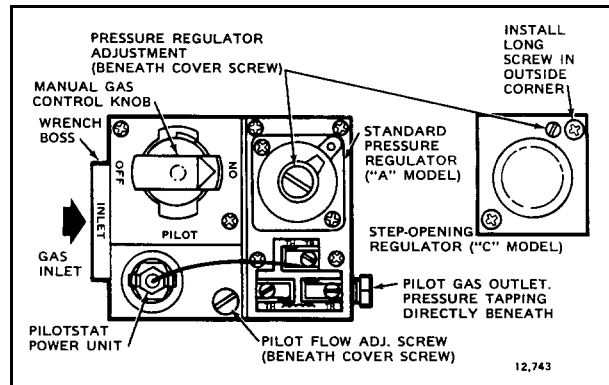

FIG. 6—TOP VIEW OF STANDARD CAPACITY GAS CONTROL.

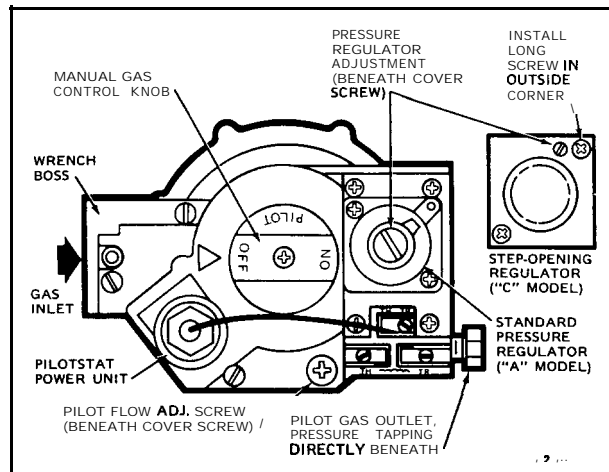

FIG. 7—TOP VIEW OF HIGH CAPACITY MODEL.

CONNECT PILOT GAS TUBING

1. Cut tubing to desired length and bend as necessary for routing to pilot burner. Do not make sharp bends or deform tubing. Do not bend tubing at control after compression nut has been tightened, as this may result in gas leakage at connection.

2. Square off and remove burrs from end of tubing.

3. Unscrew brass compression fitting from pilot gas outlet (Figs. 6 and 7). Slip fitting over tubing and slide out of way.

NOTE: When replacing a control, cut off old compression fitting and replace with new compression fitting provided on new combination gas control. Never use old compression fitting as it may not provide a gas-tight seal. Refer to Fig. 8.

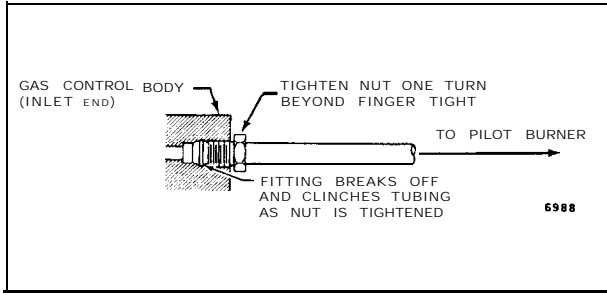

FIG. 8-ALWAYS USE NEW COMPRESSION FITTING.

4. Push tubing into pilot gas tapping on outlet end of the control until it bottoms. While holding tubing all the way in, slide fitting into place and engage threads. Turn until finger tight. Then tighten one more turn with wrench. Do not overtighten.

5. Connect other end of tubing to pilot burner according to pilot burner manufacturer's instructions.

CONNECT THERMOCOUPLE (24V, 100V, 120V, and 220/240V models)

The thermocouple connection to the power unit or ECO connector (Figs. 6 and 7) is an electrical connection and must be clean and dry. Never use pipe compound. Tighten only 1/4 turn beyond finger tight to give good electrical continuity.

CONNECT ECO (Standard capacity 24V, 100V, 120V, and 220/240 models)

If the ECO is provided, the leadwires must be equipped with insulated 1/4 in. female quick-connect terminals. Leadwire lengths must not exceed the lengths shown in Tables 5 and 6. Connect the high-limit or ECO leadwires to the two terminals on the ECO

If ECO is not provided, connect a Q313B thermopile generator in place of the thermocouple to act as the high-limit for the system.

TABLE 5—MAXIMUM LENGTH OF SUPPLEMENTARY LIMIT LEADWIRES WHEN USING Q340A THERMOCOUPLE.

THERMOCOUPLE LENGTH		MAXIMUM LEADWIRE LENGTH X 2 (wires)					
		AWG NO. 14		AWG NO. 16		AWG NO. 18	
in.	m	in.	m	in.	m	in.	m
18	0.5	35	0.9	22	0.6	13	0.3
24	0.6	29	0.7	18	0.5	11	0.3
30	0.8	23	0.6	15	0.4	9	0.2
36	0.9	17	0.4	11	0.3	6	0.2
48	1.2	DO NOT USE.					
72	1.8						

TABLE 6—MAXIMUM LENGTH OF SUPPLEMENTARY LIMIT LEADWIRES WHEN USING Q309A THERMOCOUPLE.

M COUPLE LENGTH		MAXIMUM LEADWIRE LENGTH X 2 (wires)					
		AWG NO. 14		AWG NO. 16		AWG NO. 18	
in.	m	in.	m	in.	m	in.	m
12	0.3	47	1.2	30	0.8	18	0.5
18	0.5	41	1.0	26	0.7	16	0.4
24	0.6	35	0.9	22	0.6	14	0.4
30	0.8	29	0.8	18	0.5	11	0.3
36	0.9	23	0.6	15	0.4	9	0.2
40	1.0	19	0.5	12	0.3	7	0.2
48	1.2	11	0.3	7	0.2		
60	1.5	DO NOT USE.					

WIRING

Follow wiring instructions furnished by appliance manufacturer, if available, or use general instructions provided below. Where instructions differ, follow appliance manufacturer's instructions.

All wiring must comply with applicable electrical codes and ordinances or with the National Electrical Code (ANSI/NFPA 70), whichever applies.

Disconnect power supply before making wiring connections to prevent electrical shock or equipment damage.

Wiring 24V Models

NOTE: The V800 and V801 have a blue terminal block. Terminals and markings are identical.

1. Make sure the power supply rating on each control matches the available supply. Install transformer, low voltage thermostat, and other controls as required.
2. Connect control circuit to operator terminals. Refer to Fig. 9 for typical 24V wiring diagram.
3. Adjust thermostat heat anticipator to 0.2A rating stamped on valve operator.

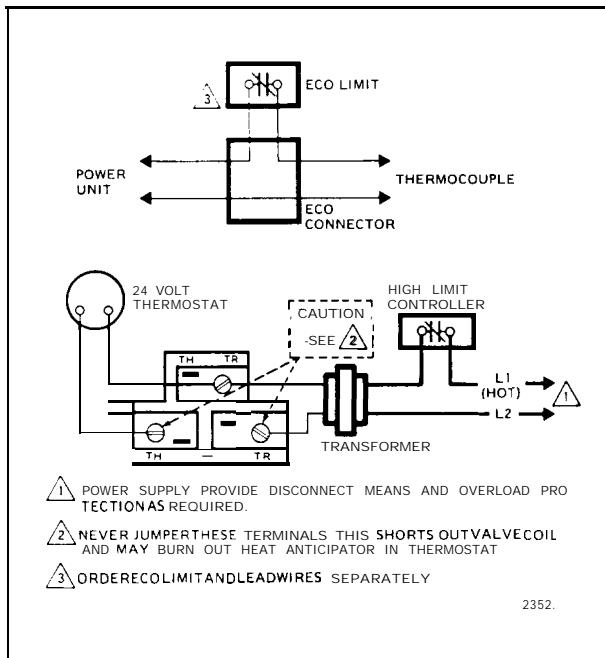

FIG. 9—TYPICAL WIRING HOOKUP FOR 24V SYSTEMS.

Wiring 110V, 120V, 220/240V Models

1. Make sure power supply rating on each control matches available supply. Install line voltage thermostat (or controller) and other controls as required. Refer to Fig. 10 for typical wiring diagram.
2. Use junction box, as shown, when connecting control circuit to gas control operator. Make conduit connection to operator as follows:
 - a. Slip conduit fittings over integral leadwires and screw securely into hole in operator cover.
 - b. Cut flexible conduit to appropriate length. Slip conduit over leadwires and attach to fittings.
 - c. Route and connect both flexible conduits to junction box. Connect integral wires to control circuit. Do not splice except within a junction box.

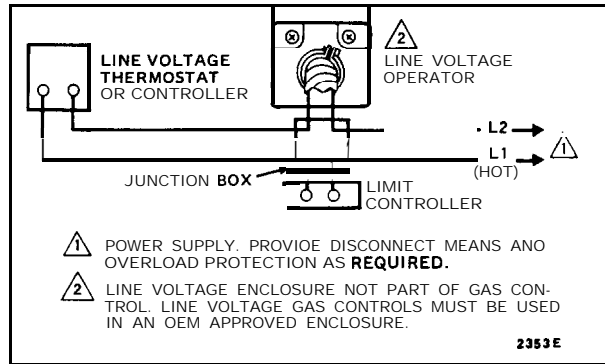

FIG. 10—TYPICAL WIRING HOOKUP FOR 120V SYSTEM.

Wiring Powerpile Models

IMPORTANT

1. Since the entire control system is powered by the millivoltage generated by the Powerpile generator, clean and scrape all wires before connecting. Solder and tape all necessary splices using rosin flux to prevent corrosion.
2. Control circuit cable length must not exceed 30 ft [9 mm] of 2-wire, 18 gauge cable, or 50 ft [15 m] of 2-wire, 16 gauge cable.

Follow appliance manufacturer's wiring instructions, if available, or use general instructions provided below. Where instructions differ, follow appliance manufacturer instructions.

Never connect these millivoltage controls to line voltage or to a transformer.

To prevent electrical shock or equipment damage, disconnect power supply before making wiring connections.

1. After Powerpile generator is installed in pilot burner, route generator lead to gas control.
2. Connect lead to gas control terminals labeled PP.
3. Connect thermostat leads as shown in Fig. 11 or 12.

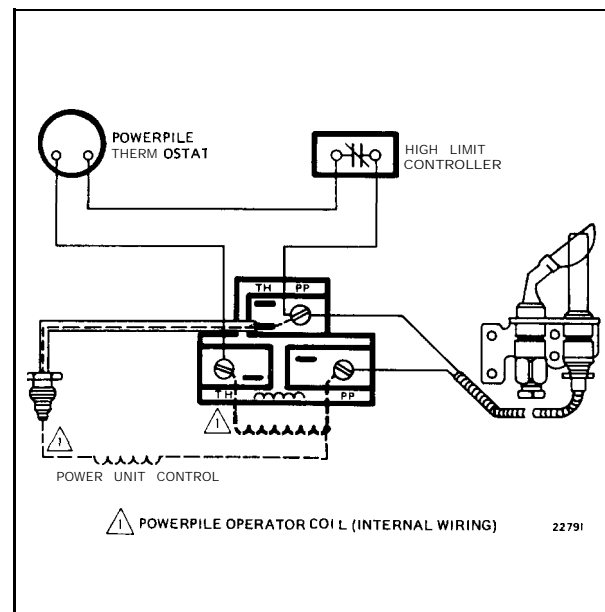

FIG. 11—TYPICAL WIRING CONNECTIONS FOR GAS CONTROL WITH THREE-TERMINAL OPERATOR.

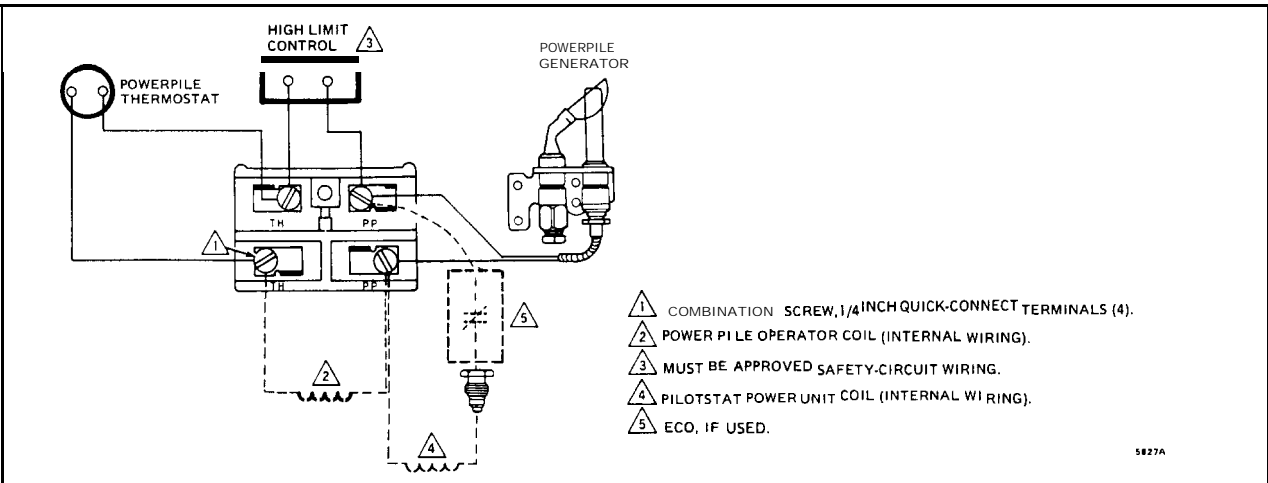

FIG. 12—TYPICAL WIRING CONNECTIONS FOR GAS CONTROL WITH FOUR-TERMINAL OPERATOR.

STARTUP AND CHECKOUT

WARNING

FIRE OR EXPLOSION HAZARD
CAN CAUSE PROPERTY DAMAGE, SEVERE INJURY, OR DEATH

1. Do not force the gas control knob. Only use your hand to push down gas control knob. Never use any tools.
2. If the gas control knob will not operate by hand, a new control should be installed by a qualified service technician.

GAS CONTROL KNOB SETTINGS

Gas control knob settings are as follows:

OFF prevents pilot and main burner gas flow from passing through valve.

PILOT permits pilot gas flow only. Gas control knob must be held depressed or thermocouple/thermopile must be heated sufficiently to hold the Pilotstat safety control valve open.

ON permits pilot or main burner gas flow into gas control body. Under control of thermostat and ignition module, gas can flow to pilot and main burners.

PERFORM GAS LEAK TEST

WARNING

FIRE OR EXPLOSION HAZARD
CAN CAUSE PROPERTY DAMAGE, SEVERE INJURY, OR DEATH

Check for gas leaks with soap and water solution any time work is done on a gas module.

GAS LEAK TEST:

1. Paint pipe connections upstream of gas control with rich soap and water solution. Bubbles indicate gas leak.
2. If leak is detected, tighten pipe connections.
3. Stand clear of main burner while lighting to prevent

injury caused from hidden leaks which could cause flashback in the appliance vestibule. Light main burner.

4. With main burner in operation, paint pipe joints (including adapters) and control inlet and outlet with rich soap and water solution.

5. If another leak is detected, tighten adapter screws, joints, and pipe connections.

6. Replace part if leak can't be stopped.

LIGHT PILOT

1. Turn gas control knob clockwise  to OFF. Wait five minutes to dissipate any unburned gas. Sniff around the appliance near the floor. Don't relight pilot if you smell gas.

2. Turn gas control knob counterclockwise  to PILOT. Push down and hold the knob while you light pilot burner.



3. Hold the gas control knob down about one minute, then release. If the pilot goes out, turn gas control knob clockwise  to OFF. Repeat steps 1-3.

4. Release gas control knob. If pilot remains lit, turn counterclockwise  to ON.

ADJUST PILOT FLAME

The pilot flame should envelop 3/8 to 1/2 in. [10 to 13 mm] of the tip of the thermocouple or generator. Refer to Fig. 13. To adjust:

1. Remove pilot adjustment cover screw. Refer to Figs. 6 or 7.

2. Turn inner adjustment screw clockwise  to decrease or counterclockwise  to increase pilot flame.

3. Always retighten cover screw after adjustment and tighten firmly to ensure proper operation.

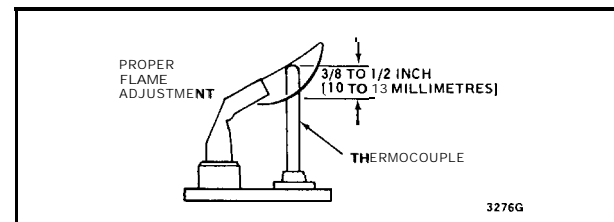

FIG. 13—PROPER FLAME ADJUSTMENT.

TURN ON MAIN BURNER

Follow instructions provided by appliance manufacturer or turn up thermostat to call for heat.



CHECK AND ADJUST GAS INPUT TO MAIN BURNER

CAUTION

1. Do not exceed input rating stamped on appliance nameplate, or manufacturer's recommended burner orifice pressure for size orifice(s) used. Make certain primary air supply to main burner is properly adjusted for complete combustion. Follow appliance manufacturer's instructions.
2. IF CHECKING GAS INPUT BY CLOCKING GAS METER: Make certain there is no gas flow through the meter other than to the appliance being checked. Other appliances must remain off with their pilots extinguished (or their consumption must be deducted from the meter reading). Convert flow rate to Btuh as described in Form 70-2602. Gas Controls Handbook, and compare to the Btuh input rating on appliance nameplate.
3. IF CHECKING GAS INPUT WITH MANOMETER: Make certain gas control is in PILOT position before removing outlet pressure tap plug to connect manometer (pressure gauge). Also turn gas control knob back to PILOT when removing gauge and replacing plug. Before removing inlet pressure tap plug, shut off gas supply at the manual valve in the gas piping to the appliance or, for LP, at the tank. Also shut off gas supply before disconnecting manometer and replacing plug. Repeat Gas Leak Test at plug with main burner operating.

Standard Pressure Regulator

1. Check the manifold pressure listed on the appliance nameplate. Gas control outlet pressure should match the nameplate.
2. With main burner operating, check gas control flow rate using the meter clocking method or pressure using a manometer connected to the outlet pressure tap on the gas control. Refer to Figs. 6 and 7.
3. If necessary, adjust pressure regulator to match appliance rating. Refer to Table 9 for factory set nominal outlet pressure and adjustment range.

- a. Remove pressure regulator adjustment cap and screw.
 - b. Using screwdriver, turn inner adjustment screw clockwise  to increase or counterclockwise  to decrease gas pressure to burner.
 - c. Always replace cap screw and tighten firmly to ensure proper operation.
4. If desired outlet pressure or flow rate cannot be achieved by adjusting the control, check the control inlet pressure using a manometer at the inlet pressure tap. If inlet pressure is in normal range (refer to Table 9), replace the control. Otherwise, take the necessary steps to provide proper gas pressure on the control.

Step-Opening Pressure Regulator



1. Check the full rate manifold pressure listed on the appliance nameplate. Gas control full rate outlet pressure should match this rating.
2. With main burner operating, check the control flow rate using the meter clocking method or pressure using a manometer connected to outlet pressure tap on the control. Refer to Figs. 6 and 7.
3. If necessary, adjust pressure regulator to match appliance rating. Refer to Table 9 for factory set nominal outlet pressure and adjustment range.
 - a. Remove pressure regulator adjustment cap screw.
 - b. Using screwdriver, turn inner adjustment screw clockwise  to increase or counterclockwise  to decrease gas pressure to burner.
 - c. Always replace cap screw and tighten firmly to ensure proper operation.
4. If desired outlet pressure or flow rate cannot be achieved by adjusting the control, check the inlet pressure using a manometer at inlet pressure tap or upstream of the gas control. If inlet pressure is in the normal range (refer to Table 9), replace the existing control. Otherwise, take the necessary steps to provide proper gas pressure to the control.
5. Carefully check burner lightoff at step pressure. Make sure burner lights smoothly and without flashback to orifice. Make sure all ports remain lit. Cycle burner several times, allowing at least 30 seconds between cycles for regulator to resume step function. Repeat after allowing burner to cool. Readjust full rate outlet pressure if necessary to improve lightoff characteristics.

TABLE 9—PRESSURE REGULATOR SPECIFICATION PRESSURES IN in. wc.

MODEL	TYPE OF GAS	NOMINAL INLET PRESSURE RANGE	OUTLET PRESSURE			
			NOMINAL FACTORY SETTING		SETTING RANGE	
			STEP	FULL RATE	STEP	FULL RATE
VS820A,H,V; VS821A	NAT	5.0-7.0	—	3.5	—	3.0-5.0
	LP	12.0 -14.0	—	11.0	—	8.0-12.0
VS820C,P VS821C	NAT	5.0-7.0	0.9	3.5	None	3.0-5.0
	LP	12.0 -14.0	2.2	11.0	None	8.0-12.0

TABLE 9A—PRESSURE REGULATOR SPECIFICATION PRESSURES IN kPa.

MODEL	TYPE OF GAS	NOMINAL INLET PRESSURE RANGE	OUTLET PRESSURE			
			NOMINAL FACTORY SETTING		SETTING RANGE	
			STEP	FULL RATE	STEP	FULL RATE
VS820A,H,V; VS821A	NAT	1.2-1.7	—	0.9	—	0.7-1.2
	LP	2.9-3.9	—	2.7	—	2.0-3.0
VS820C, VS821C	NAT	1.2-1.7	0.2	0.9	None	0.7-1.2
	LP	2.9-3.9	0.5	2.7	None	2.0-3.0

CHECK SAFETY SHUTDOWN PERFORMANCE

WARNING
<p>FIRE OR EXPLOSION HAZARD CAN CAUSE PROPERTY DAMAGE, SEVERE INJURY OR DEATH Perform the safety shutdown test any time work is done on a gas module.</p>

1. Place gas control knob in PILOT position. Main burner should go off and pilot should remain lit.
2. Extinguish pilot flame. Pilot gas flow should stop within 2-1/2 minutes. Safety shutoff of pilot gas proves complete shutdown since safety shutoff valve blocks flow of gas to main burner and pilot.
3. Relight pilot burner and operate system through one complete cycle to make sure all controls operate properly.

MAINTENANCE

WARNING
<p>FIRE OR EXPLOSION HAZARD CAN CAUSE PROPERTY DAMAGE, SEVERE INJURY, OR DEATH Improper cleaning or reassembly may cause gas leakage. When cleaning, ensure that control is reassembled properly and perform gas leak test.</p>

Regular preventive maintenance is important in applications that place a heavy load on system controls, such as in the commercial cooking and agricultural and industrial industries because:

- In many such applications, particularly commercial cooking, the equipment operates 100,000-200,000 cycles per year. Such heavy cycling can wear out the gas control in one to two years.
- Exposure to water, dirt, chemicals and heat can damage the gas control and shut down the control system.

The maintenance program should include regular checkout of the gas control as outlined under STARTUP AND CHECKOUT on page 9, and the control system as described in the appliance manufacturer's literature.

Maintenance frequency must be determined individually for each application. Some considerations are:

- *Cycling frequency.* Appliances that may cycle 100,000 times annually should be checked monthly.
- *Intermittent use.* Appliances that are used seasonally should be checked before shutdown and again before the next use.
- *Consequence of unexpected shutdown.* Where the cost of an unexpected shutdown would be high, the system should be checked more often.
- *Dusty, wet or corrosive environment.* Since these environments can cause the gas control to deteriorate more rapidly, the system should be checked more often.

The gas control should be replaced if:

- It does not perform properly on checkout or troubleshooting.
- The gas control knob is hard to turn or push down, or it fails to pop back up when released.
- The control is likely to have operated for more than 200,000 cycles.

OPERATION

The V800 combination gas control family provides 3-position (OFF-PILOT-ON) manual control of gas flow. In Fig. 14, the gas control knob is in the ON position, the pilot is proven by the thermocouple/generator, and the thermostat is calling for heat.

GAS CONTROL KNOB AT OFF

The manual safety shutoff valve and main valve are closed. No gas flows into the control.

GAS CONTROL KNOB AT PILOT

The manual safety shutoff valve and main valve are closed until the gas control knob is manually depressed. When depressed, the manual safety shutoff valve is opened, allowing pilot gas flow so the pilot can be lit. After about one minute, the thermocouple/generator current is enough so the power unit and holds the manual shutoff valve open. The main valve remains closed and prevents main burner gas flow until the thermostat calls for heat.

GAS CONTROL KNOB AT ON; NO CALL FOR HEAT

This is the standby position. The safety shutoff valve is open, but the main valve is closed. Gas flow is restricted to the pilot only.

GAS CONTROL KNOB AT ON; THERMOSTAT CALLS FOR HEAT

On a call for heat, the valve operator opens the left-hand port and closes the right-hand port. Gas flows through the working gas channel, increasing the working gas pressure. The increased pressure pushes against the main valve diaphragm, opening the main valve and permitting gas flow through the control to the main burner. The servo pressure regulator controls outlet gas pressure to the main burner.

GAS CONTROL KNOB AT OFF; THERMOSTAT ENDS CALL FOR HEAT

When a call for heat ends, the valve operator closes the left-hand port and opens the right-hand port. Gas flow through the working gas channel is reversed, decreasing the working gas pressure. The decreased pressure allows the main valve diaphragm to retract and close the main valve. The working gas flows through the evacu-

ation channel to the gas outlet to the main burner. The safety valve remains open, allowing pilot gas flow.

LOSS OF PILOT FLAME

The Pilotstat safety shutoff mechanism shuts down the combination gas control if the pilot flame becomes extinguished or too small for satisfactory burner ignition.

As the pilot burns, it constantly heats the thermocouple or Powerpile generator, providing current for the Pilotstat power unit in the gas control. A properly burning pilot supplies the power unit with enough current to keep the safety valve open and allow pilot gas flow. If the pilot goes out or decreases current to the power unit, the power unit will "drop out," closing the safety valve and preventing pilot gas flow and main burner gas flow. To restart the system, the pilot flame must be manually relit and the Pilotstat must be manually reset.

The VS820 and VS821 Powerpile models generate current independent of the line voltage and continue regulating pilot and main burner gas flow. Therefore, in a power outage, the gas control continues operating.

SERVO PRESSURE REGULATORS

When the pilot flame is burning properly and the thermostat calls for heat, the servo pressure regulator senses and varies the outlet pressure to the main burner. When the thermostat calls for heat, the valve operator ON-OFF lever opens the left-hand gas supply port, lifting the servo regulator valve off its seat and allowing gas flow into the working gas channel and evacuation channel. The working gas channel gas flow increases the pressure in the working gas pressure chamber which raises the main valve diaphragm and lifts the main valve off its seat, allowing main burner gas flow.

Outlet gas pressure variations are instantly reflected through the evacuation channel to reposition the servo regulator diaphragm. Repositioning the diaphragm adjusts the outlet pressure by altering the flow rate through the servo regulator valve.

When the outlet pressure rises, the servo regulator valve opens and allows more evacuation channel gas flow. This decreases the pressure in the working gas pressure chamber and lowers the main valve toward its seat, lowering the outlet pressure.

The opposite occurs when the outlet pressure falls. The servo regulator valve closes and allows less evacuation gas channel gas flow. This increases the pressure in the working gas pressure chamber and raises the main valve from its seat, raising outlet pressure.

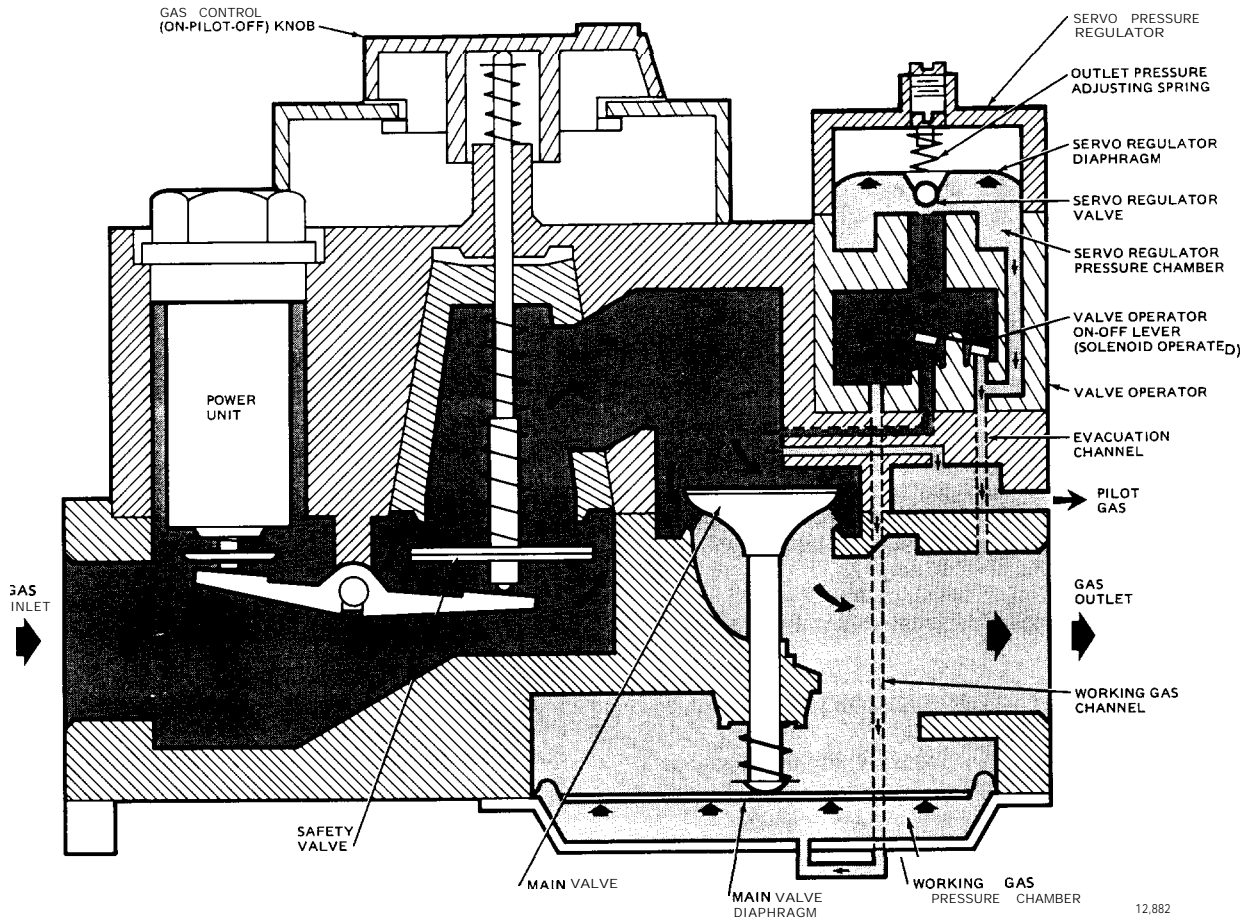

FIG. 14—GAS FLOW THROUGH THE V800 COMBINATION GAS CONTROL FAMILY.

SERVICE

WARNING

FIRE OR EXPLOSION HAZARD
CAN CAUSE PROPERTY DAMAGE, SEVERE INJURY, OR DEATH

CAUTION

Do not apply jumper across (or short) valve coil terminals, even temporarily. Doing so may burn out heat anticipator in thermostat.

IMPORTANT

Allow 60 seconds after shutdown before reenergizing step-opening model to ensure lightoff at step pressure.

IF PILOT WILL NOT LIGHT

1. Make sure the main gas supply valve is open and the pilot gas supply line is purged of air.
2. Attempt to light pilot following procedure in "Light Pilot", page 9. If pilot still will not light:
 - a. Check pilot gas adjustment screw. If closed, readjust pilot flame. Refer to page 9.
 - b. Perform gas leak test at compression fitting. If leak is detected, replace old compression fitting or tighten new one. Refer to page 7.
 - c. Ensure that pilot burner tubing or orifice is not clogged. If clogged, replace combination gas control.

IF PILOT GOES OUT WHEN GAS CONTROL KNOB IS RELEASED

1. Make sure the gas control knob is held in at least one minute to allow the thermocouple or generator time to heat.
2. Adjust thermostat several degrees above room temperature.
3. For VS820 and VS821, disconnect leadwires to lower left TH terminal and lower right PP terminal to isolate valve operator coil from balance of circuit. Measure resistance of coil. If coil is not $2\ \text{ohms} \pm 10\ \text{percent}$, replace VS824A Valve Operator.
4. In Powerpile applications, ensure jumper between valve operator and power unit is secure and connections are clean.
5. In thermocouple applications, ensure connection to power unit is tightened $1/4$ turn beyond finger tight.
6. If pilot still goes out, measure the open and closed thermocouple or generator circuit output voltages. Compare to acceptable range charts in the thermocouple or generator specifications or in the Gas Controls Handbook. Replace the thermocouple or generator if voltages are outside the acceptable range.
7. Check power unit resistance. If above 11 ohms, replace gas control,

IF MAIN BURNER WILL NOT COME WITH CALL FOR HEAT

1. Make sure gas control knob is in the ON position.
2. Adjust thermostat several degrees above room temperature.

3. For VS820 and VS821, disconnect leadwires to lower left TH terminal and lower right PP terminal to isolate valve operator coil from balance of circuit. Measure resistance of coil. If coil is not $2\ \text{ohms} \pm 10\ \text{percent}$, replace VS824A Valve Operator.

4. For all other models, use an ac voltmeter to measure voltage across terminals TH and TR. If:

- a. No voltage is present, check the control circuit for proper operation.
- b. 24 Vac is present, but first operator did not "click" open, check for excessive inlet gas pressure. If inlet pressure is correct, replace the control.
- c. 24 Vac is present and first valve operator "clicked" open, replace second operator assembly.

5. Measure the open and closed thermocouple or generator output voltages and compare to acceptable range charts in the thermocouple or generator specifications or in the Gas Controls Handbook. Replace the thermocouple or generator if voltages are outside the acceptable range.

IF BURNER IS OVERFIRING

Adjust pressure regulator to correct pressure. If regulator cannot be adjusted and supply pressure is in normal range, replace complete gas control.

INSTRUCTIONS TO THE HOMEOWNER

WARNING

FIRE OR EXPLOSION HAZARD
CAN CAUSE PROPERTY DAMAGE, SEVERE INJURY, OR DEATH

Follow these warnings and lighting instructions **exactly**:

1. **Before lighting, smell all around the appliance area for gas. If appliance uses LP (bottled) gas, also be sure to smell next to floor because LP gas is heavier than air. If you smell gas, immediately shut off the manual valve in the gas piping to the appliance. ON LP SYSTEMS, AT THE TANK. Do not try to light any appliances in the house. Do not touch electrical switches or use the phone. LEAVE THE BUILDING and call your gas supplier from a neighbor's house. If your gas supplier cannot be reached, call the fire department.**
2. **Do not force the gas control knob on the appliance. Use only your hand to push down or turn the gas control knob. Never use any tools. If the gas control knob will not operate by hand, the control should be replaced by a qualified service technician. Force or attempted repair may result in fire or explosion.**
3. **The control must be replaced if it has been flooded with water.**
4. **The control is a SAFETY DEVICE. It must be replaced in case of any physical damage, tampering, bent terminals, missing or broken parts, stripped threads, or evidence of exposure to heat.**

IMPORTANT

Follow the appliance manufacturer's instructions. The information below will assist in typical control applications, but the specific controls may require special manufacturer instructions.

LIGHTING THE MAIN BURNER

STOP: Read the warning above.

This appliance has a pilot burner which must be lit by hand. If the pilot flame has gone out, follow these instructions exactly.

1. Set the thermostat to lowest setting.
2. Turn off all electric power to the appliance.
3. Remove control access panel.
4. Push in gas control knob (refer to Fig. 3 or 4) slightly and turn clockwise  to OFF.

NOTE: Knob cannot be turned from PILOT to OFF unless knob is pushed in slightly. Do not force.

5. Wait five (5) minutes to clear out any gas. If you then smell **gas**, STOP! Follow item 1 in the Warning (page 14). If you don't smell gas, go to next step.

6. Remove the pilot access panel located below and behind the gas control unit.

7. Find the pilot—follow metal tube from gas control. The pilot is between the two burner tubes behind the pilot access panel.

8. Turn knob on gas control counterclockwise  to PILOT.

9. Push in control knob all the way and hold in. Immediately light the pilot with a match. Continue to hold the control knob in for about one (1) minute after the pilot is lit. Release knob and it will pop back up. Pilot should remain lit. If it goes out, repeat steps 5-10.

10. Replace pilot access panel.

11. Turn gas control knob counterclockwise  to ON.

12. Replace control access panel.

13. Turn on all electric power to the appliance.

14. Set thermostat to desired setting.

To Turn Off Appliance

VACATION SHUTDOWN—Set thermostat to desired control temperature while you are away.

COMPLETE SHUTDOWN—Push in gas control knob slightly and turn clockwise  to OFF. Do not force. Appliance will completely shut off. Follow lighting procedure above to resume normal operation,